



Bag grippers

Handling of non-rigid goods



View of the suction chamber

Product Description

- > Handling of limp, non-rigid objects such as bags, shrink-wraps or any product that fully covers the suction cell
- > On board vacuum generation via high performance ejectors for optimum suction power
- > Dust-resistant design
- > Foam pad with optimum adjustment to product surface - easy to replace
- > Optional side channel blower for handling very porous goods

Note

- On request:
- > Splitting of suction chamber for multi-zone picking and release or product adjustment
 - > Depth of the suction chamber can be adjusted for optimum handling of specific products

Technical Data

Item no.	Air consumption at 87 psi [scfm]	Max. gripping force [N] at 60 % vacuum (-8.7 psi)			Suitable seal collars
		Dense products (e.g. steel)	Semi-porous products (e.g. wood)	Porous products (e.g. carton boxes)	
TG100x250	3.7	280	170	70	PPF100x250
TG150x300	7.4	500	300	125	PPF150x300
TG200x350	7.4	770	470	190	PPF200x350
TG250x400	7.4	1100	670	270	PPF250x400
TG300x500	7.4	1670	1000	400	PPF300x500
TG400x600	7.4	2670	1600	625	PPF400x600

Seal collars

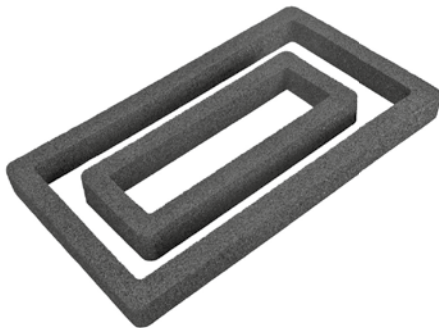

Easy replacement of seal collars



Dimensions

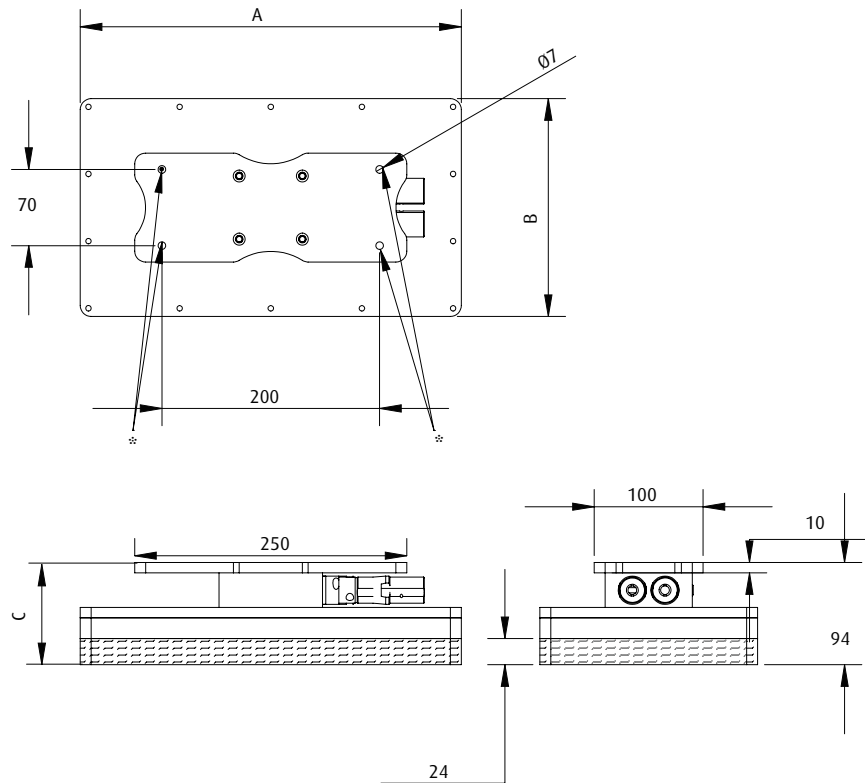

* = Customer attachment location

Item no.	A [mm]	B [mm]	C [mm]
TG100x250	100	250	62
TG150x300	150	300	62
TG200x350	200	350	62
TG250x400	250	400	93
TG300x500	300	500	93
TG400x600	400	600	93